



ASTRA-A RPA

Signaling line extender

User guide



This user guide is intended to study the principle of operation, proper use, storage and maintenance of the signalling line extender Astra-A RPA.

Abbreviations:

SLC – Signaling Line Circuit

Addressable devices – Astra-42A smoke fire detectors, Astra-43A heat fire detectors, Astra-45A fire manual call point, Astra-BRA relay unit, Astra-MA addressable marks, Astra-BPA – addressable signal relay unit;

ILS – short circuit isolator Astra-A ILS;

Tutorial – tutorial built into the Astra Pro PKM Setup Module, or Astra-812 Pro Setup Instructions;

Control Panel – control panel and fire control device Astra-812 Pro or Astra-8945 Pro with firmware version v5_6 and higher;

PKM Astra Pro – configuration and monitoring software (available on the website www.teko.biz);

PC – personal computer ;

Software – Configuration and monitoring Software;

RPA – signaling line extender.



1 Function

1.1 The RPA is designed to collect information from two SLC lines by polling all registered addressable devices one by one for changes in the state and transmitting this information via the RS-485 interface to the control panel.

1.2 The number of RPA connected to one control panel - up to **16* pcs.** (If the built-in radio module of the Control Panel is disabled).

1.3 RPA consists of:

- two RS-485 communication interfaces with built-in isolators for connecting to the control panel* and organizing a ring interface,
- two independent SLC interfaces with built-in short circuit isolators: SLC1 and SLC2,
- power supply for addressable devices of two SLC with overload protection,
- USB port for firmware update.

1.4 RPA provides isolation of the SLC section, the RS-485 interface, in which a short circuit has occurred.

1.5 RPA provides a setting of the SLC operation mode:

- "Ring SLC1-SLC2" mode (by default) - connection of up to 250 (no more than 96 "Astra-BRA" and no more than 96 "Astra-BPA" for one RPA and Control Panel) addressable devices in the "ring" topology, the length of the SLC ring is up to 1000 m;
- "Individually SLC1 and SLC2" - connection of up to 250 addressable devices in each SLC (but not more than 250 in total), with the length of each SLC up to 1000 m.

1.6 RPA supports up to 32* isolators to one SLC. In each formed SLC segment (between adjacent isolators or between an isolator and RPA) there should be no more than 32 addressable devices. The cable length in a segment should not exceed 200 m.

1.7 Recommended wires for SLC: cable with two pairs of twisted cores (pairs arranged in parallel), core cross-section from 0.35 to 2.5 sq. mm. For security systems, it is permissible to use a UTP 4x2x0.5 cables. Recommended wire type to ensure maximum range for SLC in fire systems is FRLS (FRHF, FRLSLtx), 2x2x0.5

1.8 RPA has two independent power inputs (main and backup) and automatically switches from the main input to the backup and back when the voltage drops.

RPA is powered from external redundant power sources with a rated voltage of 12 V or 24 V.

2 Specification

Power supply voltage, V.....	from 11 to 27
Consumption, mA, without connecting addressable devices to SLC, not more.....	100
Average current consumption of RPA when connected on SLC of addressable devices in the amount of N pieces calculated according to the formula and is, mA, not more:	
- when powered by 12 V.....	200+0.8*N
- when powered by 24 V.....	100+0.4*N
Peak turn-on current RPA, mA, not more:	
- when powered by 12 V.....	850
- when powered by 24 V.....	450
Output voltage, V.....	27±0.5
Threshold for the start of indication of a power failure, V.....	10
Boot time, sec., not more.....	10
Maximum cable cross section for connection to terminal blocks, sq. mm, not more.....	2.5
Overall dimensions, mm, not more.....	136 × 85 × 38
Weight, kg, not more.....	0.14

Operating conditions

Temperature range, °C.....	from -30 to +55
Relative humidity, %.....	up to 93 at +40 °C without moisture condensation

3 Delivery set

Astra-A RPA.....	1 pc.
Resistor C1-4-0.5 W-100 Ohm±5%.....	2 pc.
Screw.....	4 pc.
Dowels.....	4 pc.

4 Design

4.1 RPA is designed in a form of a block consisting of a base and a removable cover. A PCB with radio elements is mounted inside the block (Pic 2).

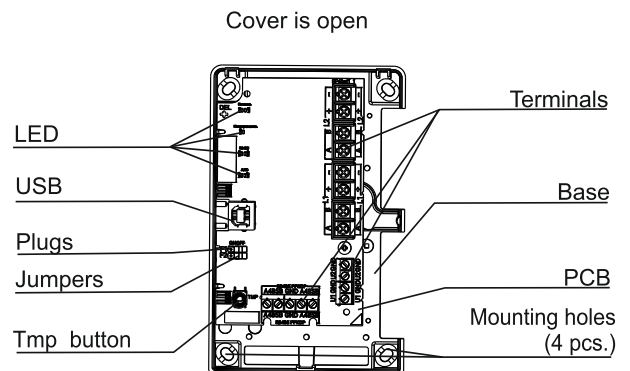

Pic. 2

4.2 Installed on the PCB:

a) LED indicators:

- **POWER** - to control the power state of the RPA;
- **FAILURE** - to control the state of the RPA
- **INTERFACE** - to control the state of the RS-485 interface line and the presence of its own registration in the Control Panel;
- **SLC** - to control the status of SLC1 and SLC2, the presence of registered devices;

b) tamper switch that generates a "Tampering" notification in case of unauthorized opening of the case;

c) plugs F1, F2, pad DEL:





- plug F1 - to update firmware,
- plug F2 - to set the operating mode (service or standby),
- contact area DEL - to restore factory settings;

d) USB connector (to change firmware)

e) terminal blocks for connecting power supply, Control Panel and two signalling lines.

* Provided in the Control Panel and RPA versions 5_6 and higher, in the settings of the Control Panel, you must set the bitrate to 38400 bps

Table 2 - Function of plugs

Plug	Function	Jumper	Note
F1	Firmware update		before power on
F2	Set operation mode		standby mode
		 (with power on)	service mode
 the jumper is installed on two pins of the plug; jumper removed (or installed for storage on one pin of the plug) 			

NOTE! When registering and in standby mode, the jumper from the F1 plug must be removed.

5 Indication

Table 3 - POWER indicator notifications and Control Panel.

Status	Power LED	Control Panel
Power-on test	1 time flash yellow then green	-
Standby mode (Power is normal)	Solid green	-
Main power failure	x1 yellow flashes every 3 sec.	+
Backup power failure	x1 flash per 1 time every 3 sec	+
Power failure	Solid yellow	+
RPA firmware update	Not on	-
«+» - the notification is sent to the Control Panel «-» - the notification is not sent to the Control Panel * a notification is issued in the event of a FAILURE or voltage drop below 10 V simultaneously on both power inputs		

Table 4 –FAILURE indicator and Control Panel notifications

Status	Failure LED	Control Panel
Power-on test	one time yellow flash	-
Any failure (tampering, SLC failure, power input failure)	Solid yellow	+
No failures	Off	-
Firmware update	Solid yellow	-
«-» - the notification is not sent to the Control Panel, «+» - the notification is sent to the Control Panel		

Table 5 - Notifications on the INTERFACE indicator and Control Panel in the service mode

Status	Interface LED	Control Panel
RPA is registered to the Control Panel		
Connection with Control Panel is normal. No activity with Control Panel on D1 and D2	x3 yellow flashes per 1 time every 3 sec.	-
Connection with Control Panel is normal. No activity with Control Panel via D1.	x1 yellow flash every 3 sec.	-
Connection with Control Panel is normal. No activity with Control Panel via D2.	x2 yellow flashes every 3 sec.	-
Connection with Control Panel is normal. Activity with Control Panel via D1 and D2.	Solid green	-

Status	Interface LED	Control Panel
No connection with Control Panel. No activity with Control Panel via D1 and D2.	Solid yellow	-
No connection with Control Panel. No activity with Control Panel via D1.	x1 yellow flash every 1 sec.	-
No connection with Control Panel. No activity with Control Panel via D2	x5 yellow flashes every 1 sec.	-
No connection with Control Panel. Activity with Control Panel via D1 and D2	x1 green flash every 1 sec.	-
RPA is not in the system		
Activity with Control Panel via D1 and D2.	Not on	-
No activity with Control Panel via D1 and D2.	x3 green flashes every 3 sec.	-
No activity with Control Panel via D1	x1 green flash every 3 sec.	-
No activity with Control Panel via D2	x2 green flashes every 3 sec.	-
«+» - the notification is sent to the Control Panel, «-» - the notification is not sent to the Control Panel D1 - incoming interface RS485 Control Panel, D2 - outgoing interface RS485 Control Panel,		

Table 6 - Notifications to the INTERFACE LED and Control Panel in standby mode

Status	INTERFACE LED	Control Panel
Power-on test	x1 yellow flash, then green flash	-
RPA is not in the system. No connection with Control Panel.	x1 green flash every sec.	-
RPA is in the system. Connection with Control Panel is fine.	Solid green	+
RPA is not in the system	Off	-
Firmware update	Off	-
«-» - the notification is not sent to the Control Panel «+» - the notification is sent to the Control Panel		

Table 7 – SLC LED and Control Panel NOTIFICATIONS

Status	SLC LED	Control Panel
Power-on test	x1 yellow flash then green flash	-
Stand By mode	Solid green	+
Line open CRC	addressable device	x1 yellow flash every 1 sec.
	No addressable device	x1 green flash every 1 sec.
Ring/beam	addressable device	Solid green
	no addressable device	Off
Addressable device registration	x1 green/yellow alternating every 1 sec.	-
Registration failure	x5 yellow flashes per 1 sec during 5 sec.	-
SLC1 Power failure	x1 green flash every 3 sec.	+

Status	SLC LED	Control Panel
Data SLC1 failure	x2 green flashes every 3 sec.	+
SLC1 General failure *	x3 green flashes every 3 sec.	+
SLC2 Failure	x1 yellow flash every 3 sec.	+
Data SLC2 failure	x2 yellow flashes every 3 sec.	+
General failure SLC2*	x3 yellow flashes every 3 sec.	+
SLC1 and SLC2 failure	1/2/3 times green/yellow flashes alternation with a period of 3 sec.	+
Software change	Not on	-
«+» - the notification is sent to the Control Panel «-» - the notification is not sent to the Control Panel		
* notification is issued when there is a simultaneous presence of power supply and data line failures.		

6 Prepare for operation

Before starting registration, you should update the version of the RPA firmware according to the method of clause 8.

6.1 Adding to the system

- 1) Check the position of the jumper on the plug F1, must be removed.
- 2) Connect RPA to Control Panel via RS-485 interface.
- 3) Turn on the power supply of the RPA and Control Panel (if it was turned off).
- 4) Run the Configuration Module utility from the Astra Pro PKM kit on the PC.
- 5) In the menu of the Configuration Module, select the item "Hard-wired devices" / "List of hardwired devices".
- 6) Place the cursor on the selected free cell of the address from the list of devices, right-click to open the menu and select the item "Register device".
- 7) Check in PKM Astra Pro how the registration passed: in case of successful registration on the PC in the program window, the entry "RPA" will appear in the selected line of the list of registered devices; in case of unsuccessful registration, it is necessary to repeat the registration procedure (steps 6, 7).

The procedure is accompanied by messages: "In progress", "Completed" or "Not completed".

Note!

RPA is ready for registration of detectors in it 60 sec after the power is turned on.

Attention!

Do not turn off the power until the end of registration and configuration of all devices in the system! In case of unsuccessful registration, it is necessary to perform the procedure for restoring the RPA factory settings according to the method of clause 7 and repeat the registration.

At the end of the registration, if it is necessary to store the RPA for a long time before using it at the facility, it is allowed to turn off its power. When the power is turned on, re-registration in the same control panel is not required if the RPA was not forcibly removed from the control panel via the Astra Pro PKM or the Astra-812 Pro menu.

6.2 Removing RPA

- a) If the RPA is connected to the Control Panel, then the removal of the RPA from the memory of the Control Panel is done through the Configuration Module of the **PKM Astra Pro** software or from the menu of the Control Panel Astra-812 Pro.
- b) If the RPA is not connected to the Control Panel:
 - remove the RPA from the memory of the Control Panel via PKM Astra Pro or from the menu of the Control Panel Astra-812 Pro;
 - reset factory settings of the RPA according to clause 7.

7 Restoring factory settings

- 1) turn on RPA power;
- 2) remove the RPA cover;
- 3) close the DEL contact pad for 5 sec, the INTERFACE indicator should flash alternately yellow / green x1 every sec, open the DEL contact pad when the indication starts ;
- 4) within 5 sec (while the indication is running), press and release the tamper switch for 1 sec. On the **FAILURE** indicator, the **yellow** color indication will turn on for **up to 15 seconds**, then the "Power-on test" indication will turn on. After turning off the indication, the factory settings are restored and the RPA is ready for registration.

8 Firmware update

Attention!

It is not recommended to update the software of a working RPA with registered detectors without special instructions from technical support specialists.

Actions needed:

- 1) install on the PKM Astra Pro computer according to the method of the Astra Pro software package (PKM) (located on the website www.teko.biz).
- 2) Turn off the RPA power;
- 3) remove the RPA cover;
- 4) install a jumper on the F1 plug;
- 5) turn on RPA power;
- 6) connect RPA to PC USB;
- 7) run the Firmware update module of the Astra Pro PKM;
- 8) select the firmware file with the required version and start the firmware update procedure;
- 9) after completing the firmware update procedure, turn off the RPA power, close the Firmware update module;
- 10) disconnect RPA from PC USB;
- 11) remove the jumper from the plug F1;
- 12) turn on the power (if necessary).

9 Installation

9.1 The wires of the power supply circuits and the RS-485 RPA interface should be located away from powerful power and high-frequency cables.

9.2 When installing, it is allowed to use mounting devices (cabinets, boxes, etc.)

9.3 Installation procedure

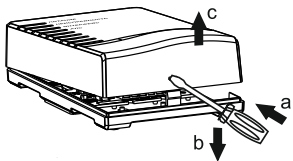
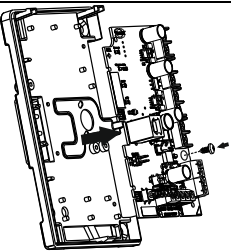
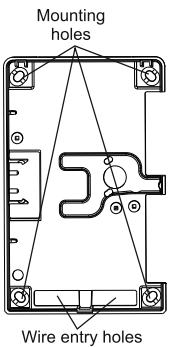
<p>1 Push the base latch out of the slot in the cover. Remove the cover</p>	
<p>2 Remove the PCB by unscrewing the screw securing the PCB to the base</p>	
<p>3 Make markings at the attachment point, using the RPA base as a stencil. Pass the wires for power supply, interface and data communication lines through the wire entry holes in the base of the RPA. Fix the base in the place chosen for this.</p>	
<p>4 Install the PCB in place; tighten the screw that secures it to the base.</p>	

5 Connect wires to terminal blocks

Name		Terminal function
SLC 1	A, B	Connecting the data SLC1
	+, -	Connecting the power SLC1
SLC 2	A, B	Connecting the data SLC2
	+, -	Connecting the power SLC2
U1, GND		Input for connecting the main power supply
U2, GND		Input for connecting a backup power supply
A485B, GND, A485B		RS-485 interface for connecting to the control panel and organizing a ring interface (terminals SLC for connecting incoming and outgoing interfaces are chosen arbitrarily)

6 Register the RPA in the Control Panel see p. 6.1.

7 Test the RPA

- 1) Check according to the indication on the RPA, in the PKM Astra Pro or on the screen "Astra-812 Pro" the status of the RPA (the status "Normal" should be displayed)
- 2) Run test mode according to User guide. Control the issuance of notifications on the Control Panel

9.4 If the length of the radial topology SLC is more than 800 m, it is recommended to install a 100 Ohm terminating resistor (from the delivery set) at the SLC point farthest from the RPA to match the Data line.

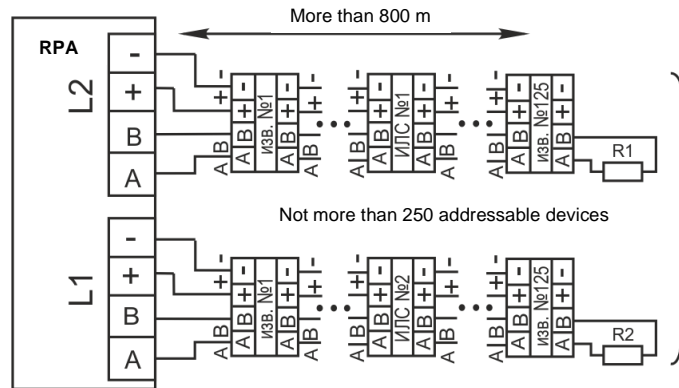

R1, R2 – resistor 100Ohm.

Pic.3

10 Warranty

The operation warranty period is 5 years from the date of operation start-up, but no longer than 5 years 6 months from the date of manufacturing subject to the requirements of User guide

Manufacturer:
 ZAO NTC TEKCO
 420108, Russia, Kazan,
 Gafuri str., 71
 Tel.: +7(843) 528-03-69
export@teko.biz
www.teko.biz

Made in Russia